

3通法蘭端口球閥 | 3 Way Flanged End Ball Valve

A3W-FE

產品特點 Feature

壓力等級：ANSI 150/300, PN16/40
JIS 10K
規格：1/2"~8" (DN15~DN200)
全流量、標準流量
端口：法蘭
ISO 5211 驅動平台
防爆軸心

Rating: ANSI 150/300, PN16/40
JIS 10K
Size: 1/2"~8" (DN15~DN200)
Full Port, Standard Port
Flanged end
ISO 5211 direct mounting pad
Blow-out-proof Stem

產品規格 Specification

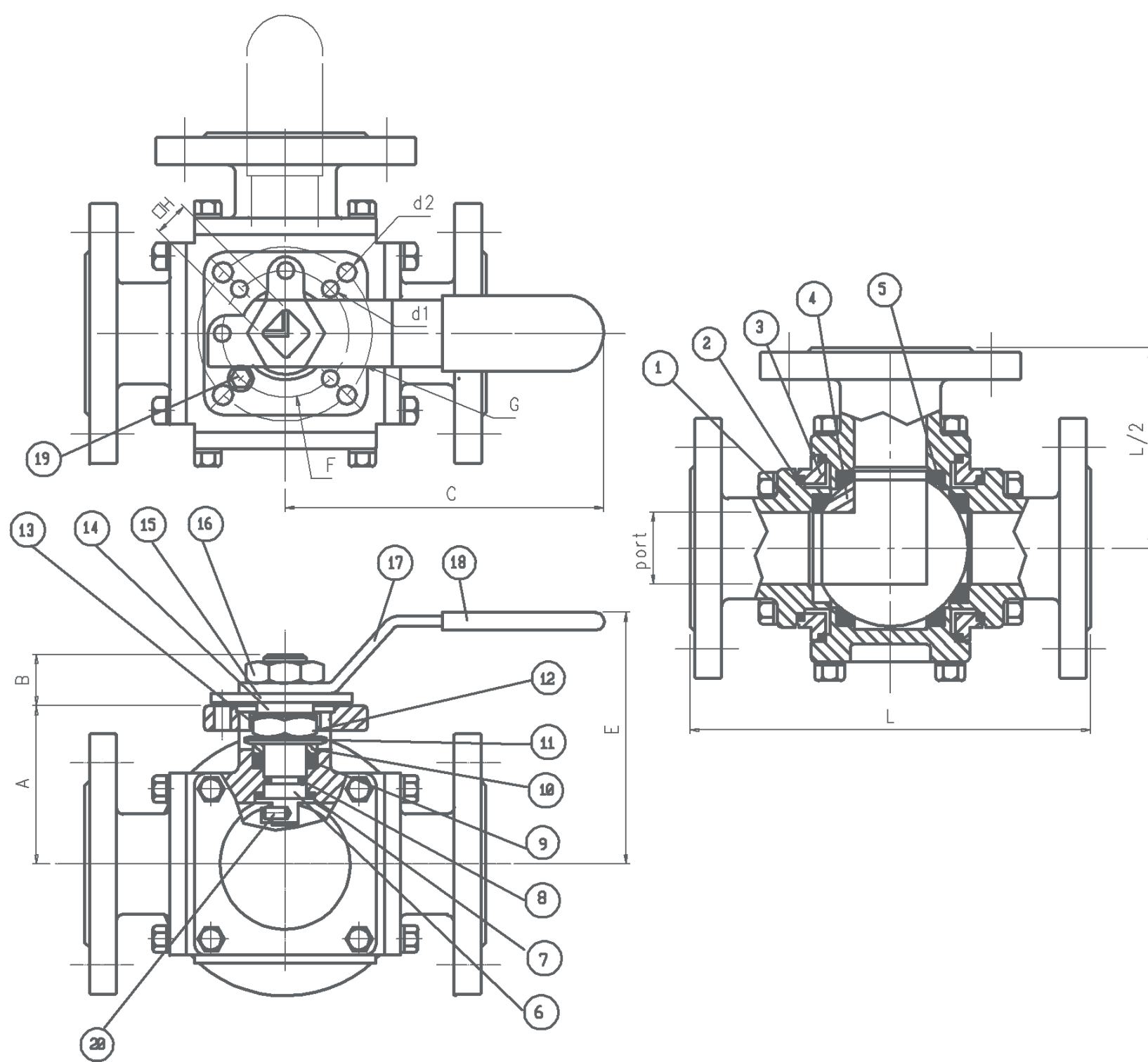

Item	Parts Name	零件名稱	Material 材料	
			Stainless Steel 不鏽鋼	Carbon Steel 碳鋼
1	Flanged end	法蘭端	A351 Gr. CF8M	A216 Gr. WCB
2	Gasket	大薄片	PTFE	PTFE
3	Body	本體	A351 Gr. CF8M	A216 Gr. WCB
4	Ball	球	SS316	SS304
5	Seats	球座	PTFE	PTFE
6	Stem Nut	軸心	SS316	SS304
7	Thrust washer	小薄片	RPTFE	RPTFE
8	O-ring	O型環	VITON	VITON
9	Stem Packing	中口	PTFE	PTFE
10	Gland	套筒	SS304	SS304
11	Disc Washer	盤型華司	SS301	SS301
12	Stem Nut	中口螺帽	SS304	SS304
13	Nut Stop	雙舌墊圈	SS304	SS304
14	Space Washer	套筒	SS304	SS304
15	Platter	檔板	SS304	SS304
16	Handle Nut	中口螺帽	SS304	SS304
17	Handle	把手	SS304	SS304
18	Cover	把手套	PLASTIC	PLASTIC
19	Stop Pin	檔把手螺絲	SS304	SS304
20	Insert Pin	靜電子	SS316	SS316

Dimension 尺寸

Unit : mm

Item Size	NPS	A	B	C	d1	d2	E	G	H	Port	L		L		L J10K
											150lbs	300lbs	PN16	PN40	
1/2"	DN15	41	11	130	6.0	6.0	62	42	9	15	152	160	160	160	152
3/4"	DN20	49	14	165	6.0	7.1	82	50	11	20	167	177	177	177	167
1"	DN25	55	14	165	6.0	7.1	89	50	11	25	190	200	190	200	190
1-1/4"	DN32	63	18	205	7.1	9.2	98	70	14	32	208	210	200	218	208
1-1/2"	DN40	74	18	205	7.1	9.2	108	70	14	38	220	234	234	234	220
2"	DN50	93	23	325	9.2	11.4	140	102	17	50	253	273	273	273	254

■ We reserve the right to modify the design / specifications without previous notice for better quality.
■ 我方有權隨時變更設計/規格，以便提供品質優良的產品。